

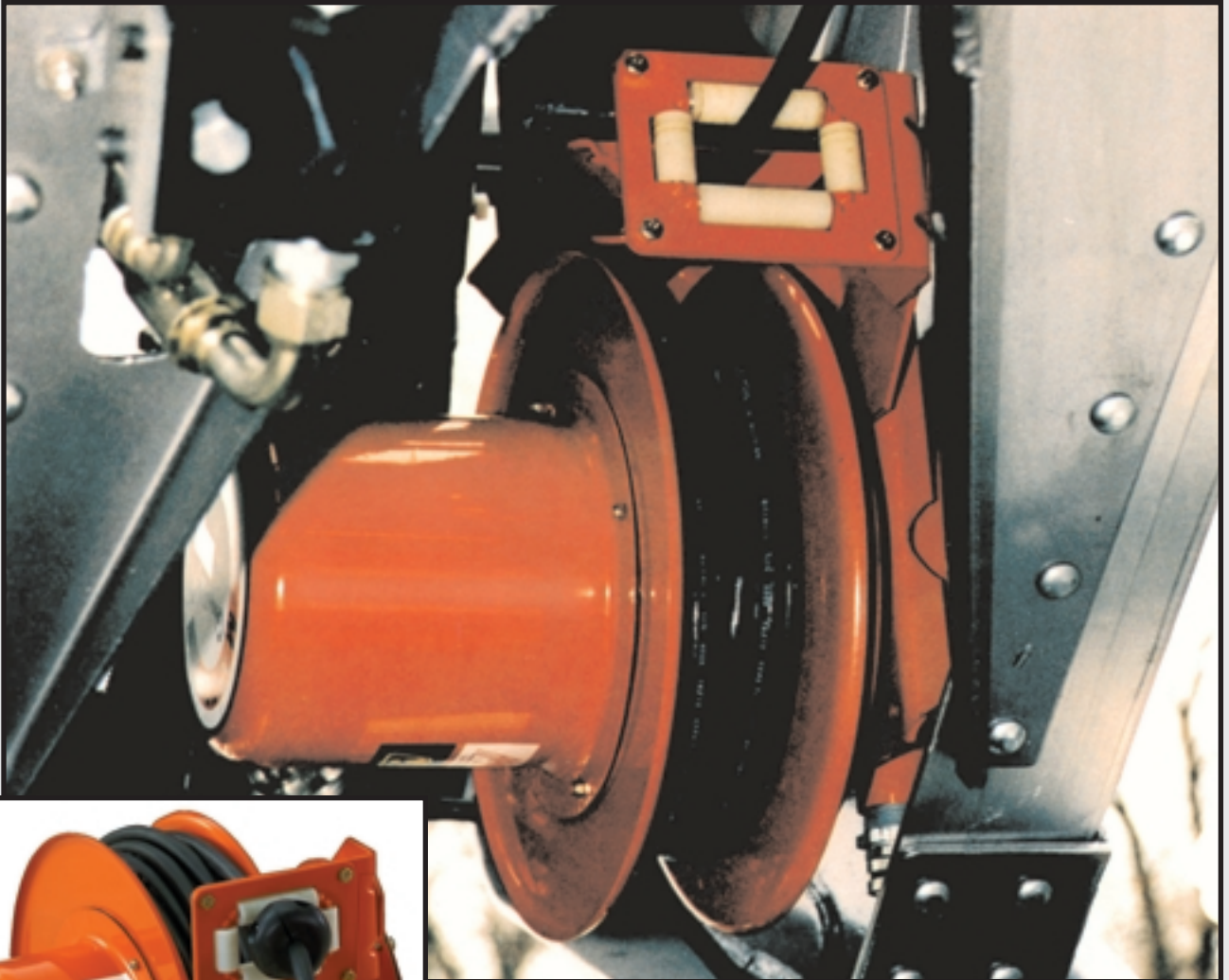

# ***Cable-Master***<sup>®</sup>

***ELECTRIC CABLE REELS***



***FEATURING:***

- ***Weather-Tight Design***
- ***Expanded Cable-Master Line***
- ***Wide Range of Compatibilities***
- ***Simplified Selection***

# Cable-Master...Your Best Buy

## Reel Specifics

Gleason Cable-Master Reels give you more for your money because they are ruggedly built and their design has been refined over many years of field use. They have either fully automatic or ratchet controlled spring rewind and contain all the features found in any reel in this size range. The photo below shows many of the important features and will also serve as a guide to identifying component parts.

**SPOOL (Standard)**– Rugged steel construction. Spools come in three diameters to accommodate a wide range of cable sizes. Formed edges protect cable. Spool sizing done by computer to ensure optimum space usage. Oversized bearings used for smooth rotation and long life.

**ROLLERED CABLE GUIDE (Standard)**–Guide controls cable during payout and rewind. Cable cannot “miss” spool, causing damage or injury. Guide may be adjusted to accommodate various reel mounting positions. Rollers on all four sides of guide assure minimum cable interference and wear.

**BAKED POLYESTER FINISH (Standard)**–All metal parts are protected against rust and corrosion by an electrostatically applied, bake on orange polyester resin finish.

**CABLE STOP (Optional extra)**– Adjustable cable stop needed only in hand pull applications. Not required in machine pull applications because machine dictates amount of cable travel.

**600 VOLT SLIP RING ASSEMBLY (Standard)**–Slip ring transfers current from the stationary source to the cable as it is being wound or unwound from the spool. Generally there is one ring per conductor.

**JUNCTION BOX (Standard)**– All steel, very roomy junction box eases installation.

**WEATHER-TIGHT SLIP RING ENCLOSURE (Standard)**– Gasketed enclosure minimizes moisture, dust or grit build up on slip rings or brushes. Increases slip ring life and reliability.

**CABLE (Extra)**– Cable is not included as standard but can be supplied, installed on reel, if desired.

**STEEL FRAME (Standard)**– Fully welded, all steel frame acts as support for all reel components.

**Not Visible on Above Photo**

**SPRING MOTOR (Standard)**– “Motor” which supplies power for rewinding cable. Spring motor is totally enclosed for safety and long life.

**RATCHET LOCK (Standard)**– Used only in hand pull applications. Holds cable at desired length while being used...is easily released to rewind cable. May be deactivated for machine pull or, if desired, for hand pull operation.

**CABLE END APPLIANCE (Optional extra)**– May be receptacle (shown), light, push button control station, etc. Needed only in hand pull applications. Not required in machine pull applications because cable is hard-wired to junction box.



**ON THE COVER:** Typical Cable-Master® reel providing power to a tool at the end of a telescoping arm.

## WARRANTY

Gleason warrants for a period of twelve (12) months after date of shipment, all goods manufactured by it to be free from defects in material and workmanship. If, within such warranty period, any such goods are proved, to Gleason's satisfaction, to be defective, such goods shall be repaired or, at Gleason's options, replaced f.o.b. Gleason's factory, without charge. Gleason's obligation hereunder shall be confined to such repair or replacement and shall be further conditioned upon Gleason's receiving written notice of any alleged defect within 10 days after its discovery and, at Gleason's option, the return of the allegedly defective goods to Gleason, f.o.b. its factory.

The foregoing warranty shall not apply to goods not manufactured by Gleason, or to goods which shall have been repaired or altered by others than Gleason so as, in Gleason's judgement, adversely affect the same, or which shall have been subject to other than normal care, or storage. With respect to goods furnished but not manufactured by Gleason, the warranty obligations of Gleason shall in all respects conform and be limited to the warranty extended to Gleason by the supplier.

The foregoing warranty is in lieu of all other express or implied warranties (except of title) and of all other obligations of Gleason.

# Selecting Cable Reels

## Cable Specifics

Whether you order the reel with cable installed or plan to put on your own, this is the place you need to start when selecting a Gleason Cable-Master Reel. What are the electrical requirements...voltage and amperage? What is the cable size? What gauge are the conductors and how many are there? Please indicate if Gleason is to supply and install cable. Cable installation is included in the price if cable is purchased with the reel.

## Type of Application

### HAND PULL or MACHINE PULL

How you use your Gleason Cable Reel matters a great deal and will affect your model choice. Proper reel application is much more than finding a spool that will hold the amount of cable you have. The proper reel strikes a delicate balance between the length and size of cable, the diameter of the spool core, the width of the spool, and the spring rate.

An all important application consideration is whether the reel will receive the somewhat erratic but controlled pull of a human or the typically constant and predictable pull of a machine. **Cable-Master Reels are designed primarily for hand pull applications but are suitable for lighter duty machine pull applications. Contact your Gleason Reel representative for information about other Gleason reels designed specifically for high speed, high duty cycle machine pull applications.**

### Hand Pull Applications

Hand pull reels have an infinite number of applications and can be mounted in a variety of ways. For proper hand pull operation, the cable guide must be used and an adjustable cable stop is highly desirable. Also, for most hand pull operations, the ratchet lock must be enabled. The ratchet lock holds cable at a desired length and can be released by a quick pull on the cable, much like raising a window shade.

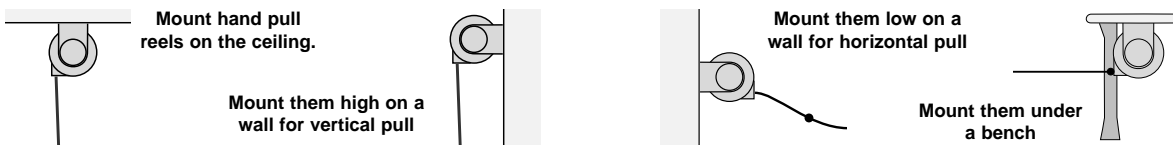

### Machine Pull Applications

#### IN-LINE PAYOUT

The simplest and most economical way to use reels for machine pull is to mount them in line with the machine so that the reel remains stationary throughout the entire travel of the machine as the cable is unspooled and respooled. This eliminates the need for accessories such as a pivot base. Note that the cable guide must be removed in the center feed application. If the cable will lay on the floor or some other support the reel should be mounted on the machine so that the cable is not dragged across the floor during use.

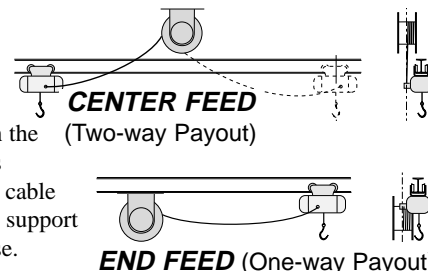

#### OFF-LINE PAYOUT

Off-line payout is used when it is not convenient to mount the reel in line with the machine it is servicing. In applications such as these, the Cable Guide (standard) and a Pivot Base (optional, extra) must be used. The pivot base allows the reel to pivot up to 340° to "follow" the hoist or other equipment. See examples at right.

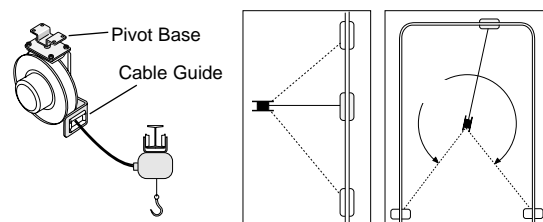

## Cable Length

To insure the proper length of cable is on your reel, you must calculate both the ACTIVE CABLE LENGTH, the length of cable that will be stored on the reel spool and unspooled during use, and the TOTAL CABLE LENGTH, active cable plus length needed at each end for hook-up. Active cable length is used to determine reel model. To find cable length, determine your ACTIVE TRAVEL distance and whether the reel will be mounted for END FEED (one-way payout) or CENTER FEED (two-way payout). Hand pull applications are almost always end feed. For end feed, active cable length is equal to active travel. For center feed (far right), active cable length is equal to **one half** the active travel length or *greatest distance from reel to machine if reel is not in exact center of machine travel*. The standard Cable Guide must be removed for center feed.

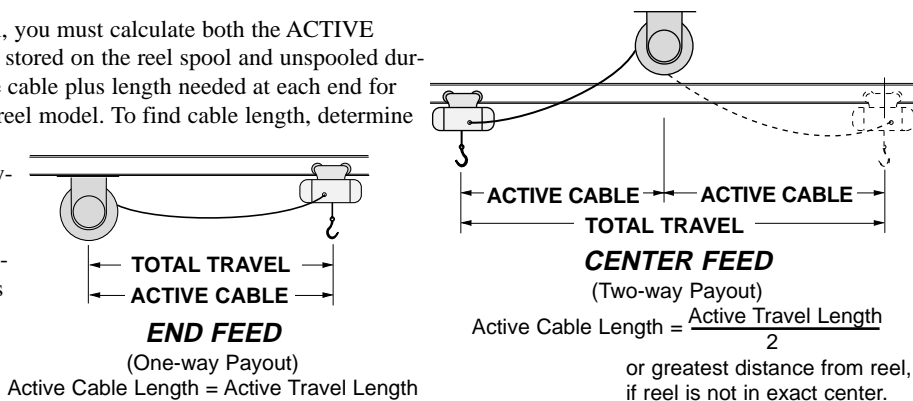

# Model Selection

Choose the correct model number from the Selection Charts below and on the following page using your cable and application information. Use model chart that corresponds to the type of application shown in one of these illustrations. Please consult Gleason Reel if you don't find a cable reel that fits your specific application. For your convenience, model number explanation is shown below.



## VERTICAL LIFT

Any application where the cable is hoisted vertically with only the weight of the cable involved. Special consideration must be given to any weight, such as tools, added to the end of the cable.



## DRAG

If the reel is stationary and the cable is pulled off the reel with the cable laying on the floor or other support, it is considered a DRAG application. Usually a hand pull application. **Having a machine drag the cable across a support is NOT recommended because of undue wear to the cable.**



## HORIZONTAL STRETCH

Stretching cable horizontally requires the greatest amount of tension of any application to maintain a minimum sag. Cable-Master reel capacities are based on 10% sag.

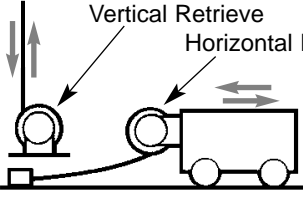

## RETRIEVE

A vertical retrieve application is much the same as a vertical lift except that the reel is located below rather than above. A horizontal retrieve application has the reel mounted on the moving equipment, paying-out cable onto the floor or other support.

## Model Number Explanation

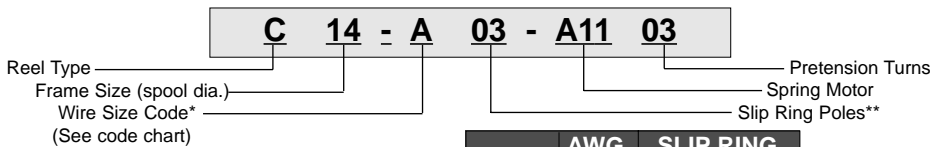

### Wire Code Sizes

\* Cable reel assembly is always derated to the maximum allowable rating of the cable.

CODE	AWG SIZE	SLIP RING MAX AMPS*
A	16	30
B	14	30
C	12	30
D	10	30
E	8W	55
F	8G	55



C14 & C16 Cable-Master Reels through #10 AWG are UL and CSA listed. Cable-Master Reel Series "C" models are designed to meet or exceed NEMA 3, NEMA 3R & NEMA 4 ratings.

## Model Numbers— LIFTING/DRAGGING APPLICATIONS Reels listed are without cable.

WIRE SIZE	No. Cond.	FEET OF ACTIVE CABLE								
		20	25	30	35	40	45	50	60	70
16	3	C14-A03-A1104	C14-A03-B1102	C14-A03-B1102	C14-A03-B1102	C14-A03-C1102	C14-A03-C1102	C16-A03-D1102	C16-A03-J1105	C19-A03-D1101
	4	C14-A04-A1105	C14-A04-B1103	C14-A04-B1103	C14-A04-C1102	C14-A04-C1102	C14-A04-C1102	C16-A04-D1102	C16-A04-J1105	C19-A04-D1101
	6	C14-A06-A1106	C14-A06-B1103	C14-A06-B1103	C14-A06-B1103	C14-A06-C1103	C14-A06-C1103	C14-A06-C1103	C16-A06-J1106	C19-A06-D1102
	8	C14-A08-A1107	C14-A08-B1104	C14-A08-B1104	C14-A08-B1104	C14-A08-C1103	C16-A08-G1105	C16-A08-G1105	C16-A08-D1102	C19-A08-G1104
	10	C14-A10-B1104	C14-A10-B1104	C14-A10-B1104	C14-A10-B1104	C16-A10-G1105	C16-A10-G1105	C16-A10-G1105	C16-A10-D1102	C19-A10-D1102
14	3	C14-B03-A1105	C14-B03-B1103	C14-B03-B1103	C14-B03-B1103	C14-B03-C1102	C14-B03-C1102	C14-B03-C1102	C16-B03-J1105	C16-B03-J1105
	4	C14-B04-A1105	C14-B04-B1103	C14-B04-B1103	C14-B04-B1103	C14-B04-C1103	C14-B04-C1103	C14-B04-C1103	C16-B04-J1107	C19-B04-G1103
	6	C14-B06-B1104	C14-B06-B1104	C14-B06-B1104	C14-B06-B1104	C16-B06-G1105	C16-B06-G1105	C16-B06-G1105	C16-B06-D1102	C19-B06-D1102
	8	C14-B08-B1107	C14-B08-B1107	C14-B08-B1107	C16-B08-G1105	C16-B08-G1105	C16-B08-G1105	C16-B08-G1105	C19-B08-H1103	C19-B08-D1105
	10	C14-B10-B1109	C16-B10-H1103	C16-B10-H1103	C19-B10-E1102	C19-B10-E1102	C19-B10-E1102	C19-B10-E1102		
12	3	C14-C03-A1105	C14-C03-A1105	C14-C03-B1103	C14-C03-B1103	C14-C03-C1106	C16-C03-G1104	C16-C03-G1104	C16-C03-K1103	C19-C03-G1103
	4	C14-C04-A1107	C14-C04-B1103	C14-C04-B1103	C14-C04-B1103	C14-C04-B1103	C16-C04-G1104	C16-C04-G1104	C16-C04-K1104	C19-C04-K1105
	6	C14-C06-B1107	C16-C06-K1104	C16-C06-K1104	C16-C06-K1104	C16-C06-K1104	C16-C06-K1104	C19-C06-H1104	C19-C06-H1104	
	8	C14-C08-B1111	C16-C08-H1103	C16-C08-H1103	C19-C08-E1102	C19-C08-E1102	C19-C08-E1102	C19-C08-E1102		
	10	3	C14-D03-B1104	C14-D03-B1104	C14-D03-B1104	C14-D03-B1104	C16-D03-G1105	C16-D03-G1105	C16-D03-G1105	C16-D03-K1104
4		C14-D04-B1107	C14-D04-B1107	C16-D04-G1105	C16-D04-G1105	C16-D04-G1105	C16-D04-G1105	C16-D04-G1105	C19-D04-H1102	C19-D04-H1102
6		C14-D06-B1111	C16-D06-H1103	C16-D06-H1103	C19-D06-E1103	C19-D06-E1103	C19-D06-E1103	C19-D06-D1111		
8		C16-D08-E1103	C19-D08-E1103	C19-D08-E1103						
8	2W	C14-E02-B1109	C14-E02-B1109	C16-E02-G1108	C16-E02-G1108	C16-E02-G1108	C16-E02-G1108	C19-E02-H1106	C19-E02-D1108	
	3W	C16-E03-H1103	C16-E03-H1103	C16-E03-H1103	C19-E03-E1103	C19-E03-E1103	C19-E03-E1103			
	*3G	C16-F04-H1106	C16-F04-H1106	C16-F04-H1106	C19-F04-E1104	C19-F04-E1104				
	4W	C16-E04-H1106	C16-E04-H1106	C16-E04-E1106	C19-E04-E1105	C19-E04-E1104				

\* If a ground check (GC) cable is used, we can supply a slip ring assembly with a fifth ring to accommodate it.

# Model Selection, con't.

NOTE: Do not factor extra cable, such as hookup, into the ACTIVE CABLE LENGTH when selecting a reel model. Add the extra cable to the active cable length only when determining total length of cable to be used with the reel. If you are supplying the cable, add cable needed for hookup at moving end plus six feet for hookup and dead wraps to active cable length. If Gleason is supplying and installing cable, be sure to indicate length of additional moving end cable on order.

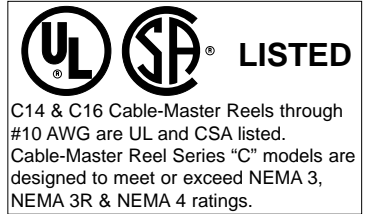

## Model Numbers—STRETCH APPLICATIONS Reels listed are without cable.

WIRE SIZE	No. Cond.	FEET OF ACTIVE CABLE								
		20	25	30	35	40	45	50	60	70
16	3	C14-A03-A1104	C14-A03-B1102	C14-A03-B1102	C14-A03-B1102	C14-A03-C1102	C14-A03-C1102	C16-A03-J1105	C16-A03-J1105	C19-A03-J1104
	4	C14-A04-A1105	C14-A04-B1103	C14-A04-B1103	C14-A04-C1102	C14-A04-C1102	C16-A04-J1106	C16-A04-J1106	C19-A04-K1103	
	6	C14-A06-A1106	C14-A06-B1103	C14-A06-B1103	C14-A06-C1103	C14-A06-C1106	C16-A06-K1104	C19-A06-G1104	C19-A06-D1102	
	8	C14-A08-B1104	C14-A08-B1104	C14-A08-B1104	C14-A08-B1104	C16-A08-G1105	C16-A08-G1105	C16-A08-G1105	C16-A08-D1102	C19-A08-D1102
	10	C14-A10-B1108	C14-A10-B1108	C16-A10-G1106	C16-A10-G1106	C16-A10-G1106	C16-A10-G1106	C16-A10-D1102	C16-A10-D1102	C19-A10-D1105
	12	C14-A12-B1109	C16-A12-G1108	C16-A12-G1108	C16-A12-G1108	C16-A12-G1108	C16-A12-H1103	C16-A12-H1103	C19-A12-D1108	
14	3	C14-B03-A1105	C14-B03-B1103	C14-B03-B1103	C14-B03-B1103	C14-B03-C1104	C14-B03-C1104	C16-B03-J1109	C19-B03-G1103	C19-B03-G1103
	4	C14-B04-A1106	C14-B04-B1103	C14-B04-B1103	C14-B04-B1103	C16-B04-G1104	C16-B04-G1104	C16-B04-G1104	C19-B04-G1106	C19-B04-D1102
	6	C14-B06-B1108	C14-B06-B1108	C16-B06-B1106	C16-B06-G1106	C16-B06-G1106	C16-B06-G1106	C16-B06-K1105	C16-B06-D1102	
	8	C14-B08-B1110	C16-B08-E1103	C16-B08-E1103	C16-B08-H1103	C16-B08-H1103	C16-B08-H1103	C16-B08-H1103		
	10	C16-B10-E1103	C16-B10-E1103	C16-B10-E1103	C19-B10-E1103	C19-B10-E1103	C19-B10-E1103			
	12	C16-B12-E1103	C16-B12-E1103	C16-B12-E1103	C19-B12-E1103	C19-B12-E1103				
12	3	C14-C03-B1103	C14-C03-B1103	C14-C03-B1103	C14-C03-B1103	C16-C03-G1104	C16-C03-G1104	C16-C03-G1104	C16-C03-D1102	C19-C03-D1102
	4	C14-C04-B1106	C14-C04-B1106	C14-C04-B1106	C16-C04-G1105	C16-C04-G1105	C16-C04-G1105	C16-C04-G1105	C16-C04-D1102	C19-C03-D1104
	6	C16-C06-E1103	C16-C06-E1103	C16-C06-E1103	C16-C06-H1103	C16-C06-H1103	C16-C06-H1103	C16-C06-D1111		
	8	C16-C08-E1103	C16-C08-E1103	C16-C08-E1103	C19-C08-E1103	C19-C08-E1103	C19-C08-E1103			
10	3	C14-D03-B1108	C14-D03-B1108	C16-D03-G1105	C16-D03-G1105	C16-D03-G1105	C16-D03-G1105	C16-D03-G1105	C16-D03-D1102	
	4	C14-D04-B1110	C14-D04-G1109	C16-D04-G1109	C16-D04-G1109	C16-D04-G1109	C16-D04-H1103	C16-D04-H1103		
	6	C16-D06-E1103	C16-D06-E1103	C16-D06-E1103	C19-D06-E1103	C19-D06-E1103				
	8	C16-D08-E1103	C19-D08-E1107	C19-D08-E1107						
8	2W	C16-E02-H1104	C16-E02-H1104	C16-E02-H1104	C16-E02-H1104	C16-E02-H1104	C16-E02-H1104			
	3W	C16-E03-E1103	C16-E03-E1103	C16-E03-E1103	C19-E03-E1105					
	*3G	C16-F04-E1103	C16-F04-E1103	C16-F04-E1103						
	4W	C16-E04-E1103	C16-E04-E1103	C16-E04-E1103						

## Model Numbers—RETRIEVE APPLICATIONS Reels listed are without cable.

WIRE SIZE	No. Cond.	FEET OF ACTIVE CABLE								
		20	25	30	35	40	45	50	60	70
16	3	C14-A03-A1104	C14-A03-B1102	C14-A03-B1102	C14-A03-B1102	C14-A03-C1102	C14-A03-C1102	C16-A03-K1103	C16-A03-J1105	C19-A03-K1102
	4	C14-A04-A1105	C14-A04-B1103	C14-A04-B1103	C14-A04-C1103	C14-A04-C1103	C14-A04-C1103	C16-A04-K1103	C16-A04-J1106	C19-A04-K1103
	6	C14-A06-B1104	C14-A06-B1104	C14-A06-B1104	C14-A06-C1103	C14-A06-C1103	C14-A06-C1103	C16-A06-C1103	C16-A06-J1107	C19-A06-K1103
	8	C14-A08-B1104	C14-A08-B1104	C14-A08-B1104	C14-A08-B1104	C14-A08-C1104	C16-A08-G1105	C16-A08-G1105	C16-A08-K1104	C19-A08-K1104
	10	C14-A10-B1105	C14-A10-B1105	C14-A10-B1105	C14-A10-B1105	C16-A10-G1106	C16-A10-G1106	C16-A10-G1106	C16-A10-K1105	C19-A10-K1104
	12	C14-A12-B1105	C14-A12-B1105	C14-A12-B1105	C14-A12-B1105	C16-A12-G1106	C16-A12-G1106	C16-A12-G1106	C19-A12-G1106	C19-A12-K1105
14	3	C14-B03-A1105	C14-B03-B1103	C14-B03-B1103	C14-B03-B1103	C14-B03-C1103	C14-B03-C1103	C14-B03-C1103	C16-B03-J1106	C19-B03-G1103
	4	C14-B04-A1106	C14-B04-B1103	C14-B04-B1103	C14-B04-B1103	C14-B04-C1103	C14-B04-C1103	C14-B04-C1103	C16-B04-J1107	C19-B04-K1103
	6	C14-B06-B1105	C14-B06-B1105	C14-B06-B1105	C14-B06-B1105	C16-B06-G1106	C16-B06-G1106	C16-B06-G1106	C16-B06-K1104	C19-B06-K1104
	8	C14-B08-B1105	C14-B08-B1105	C14-B08-B1105	C16-B08-G1106	C16-B08-G1106	C16-B08-G1106	C16-B08-G1106	C19-B08-G1106	C19-B08-K1105
	10	C14-B10-B1106	C16-B10-G1106	C16-B10-G1106	C19-B10-E1103	C19-B10-E1103	C19-B10-E1103	C19-B10-G1106		
	12	C14-B12-B1107	C16-B12-E1103	C16-B12-E1103	C19-B12-E1103	C19-B12-E1103	C19-B12-E1103	C19-B12-G1107		
12	3	C14-C03-A1106	C14-C03-B1104	C14-C03-B1104	C14-C03-B1104	C14-C03-C1103	C14-C03-C1103	C16-C03-D1102	C16-C03-D1102	C19-C03-G1104
	4	C14-C04-A1107	C14-C04-B1104	C14-C04-B1104	C14-C04-B1104	C14-C04-C1103	C16-C04-G1105	C16-C04-G1105	C16-C04-D1102	C19-C04-D1102
	6	C14-C06-B1105	C16-C06-E1103	C16-C06-E1103	C16-C06-G1106	C16-C06-G1106	C16-C06-G1106	C19-C06-G1106	C19-C06-G1106	C19-C06-G1106
	8	C14-C08-B1106	C16-C08-E1103	C16-C08-E1103	C19-C08-E1103	C19-C08-E1103	C19-C08-E1103	C19-C08-G1107		
10	3	C14-D03-B1104	C14-D03-B1104	C14-D03-B1104	C14-D03-B1104	C16-D03-G1106	C16-D03-G1106	C16-D03-D1102	C16-D03-D1102	C19-D03-D1102
	4	C14-D04-B1105	C14-D04-B1105	C14-D04-B1105	C16-D04-B1105	C16-D04-G1106	C16-D04-G1106	C16-D04-G1106	C19-D04-G1105	C19-D04-G1105
	6	C14-D06-B1107	C16-D06-E1103	C16-D06-E1103	C19-D06-E1103	C19-D06-E1103	C19-D06-G1107	C19-D06-G1107		
	8	C16-D08-E1104	C19-D08-E1104	C19-D08-E1104						
8	2W	C14-E02-B1105	C16-E02-E1103	C16-E02-E1103	C16-E02-G1106	C16-E02-G1106	C16-E02-G1106	C19-E02-G1106	C19-E02-G1106	C19-E02-G1106
	3W	C14-E03-B1107	C16-E03-E1103	C16-E03-E1103	C19-E03-E1103	C19-E03-E1103	C19-E03-E1103	C19-E03-G1107		
	*3G	C16-F04-E1104	C16-F04-E1104	C16-F04-E1104	C19-F04-E1104	C19-F04-E1104	C19-F04-G1109			
	4W	C16-E04-E1104	C16-E04-E1104	C19-E04-E1104	C19-E04-E1104	C19-E04-E1104	C19-E04-G1109			

\* If a ground check (GC) cable is used, we can supply a slip ring assembly with a fifth ring to accommodate it.



# Dimensional Data

Dimensions in inches (mm) unless otherwise noted.

## C14 Cable-Master

### Dimensions A & B

Slip Ring Enclosure—C14 Reels

WIRE SIZE CODE*	SLIP RING POLES**	A	B
A, B, C, D	1 - 4	4.50 (114)	5.69 (145)
A, B, C, D	5 - 8	6.00 (152)	7.19 (183)
A, B, C, D	9 - 12	7.50 (191)	8.69 (221)
E, F	1 - 4	6.00 (152)	7.19 (183)

### Reel Weight

Less Cable

Example:

**C14 - A03 - C** 1103

REEL MODEL	WEIGHT lbs	WEIGHT (kg)
C14 - A	40	(18)
C14 - B	42	(19)
C14 - C	47	(21)

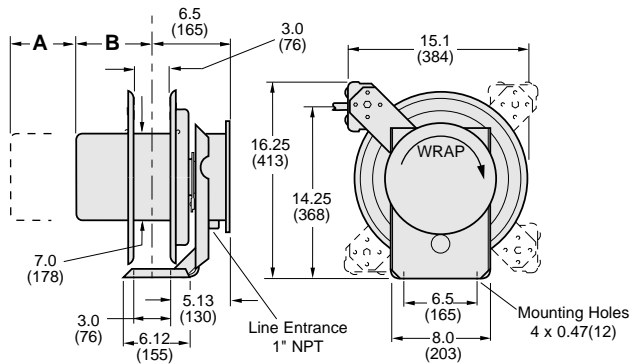

## C16 Cable-Master

### Dimensions A & B

Slip Ring Enclosure—C16 Reels

WIRE SIZE CODE*	SLIP RING POLES**	A	B
A, B, C, D	1 - 4	4.50 (114)	5.94 (151)
A, B, C, D	5 - 8	6.00 (152)	7.44 (189)
A, B, C, D	9 - 12	7.50 (191)	8.94 (227)
E, F	1 - 4	6.00 (152)	7.44 (189)

### Reel Weight

Less Cable

Example:

**C16 - A03 - J** 1105

REEL MODEL	WEIGHT lbs	WEIGHT (kg)
C16 - D	78	(35)
C16 - E	59	(27)
C16 - G	65	(29)
C16 - H	68	(31)
C16 - J	75	(34)
C16 - K	75	(34)

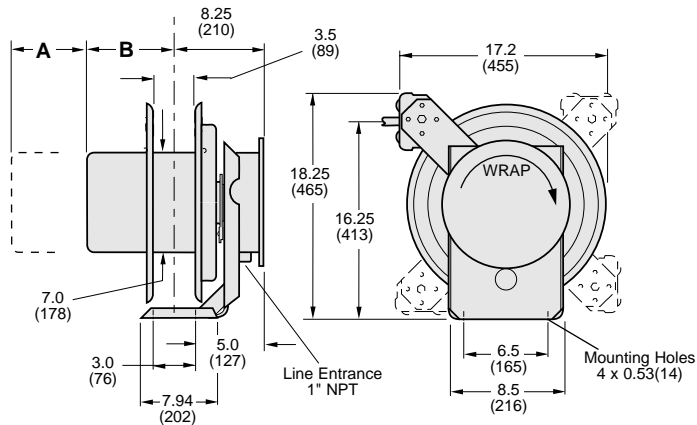

## C19 Cable-Master

### Dimensions A & B

Slip Ring Enclosure—C19 Reels

WIRE SIZE CODE*	SLIP RING POLES**	A	B
A, B, C, D	1 - 4	3.25 (83)	5.44 (138)
A, B, C, D	5 - 8	4.50 (114)	6.69 (170)
A, B, C, D	9 - 12	6.00 (152)	8.19 (208)
E, F	1 - 4	4.50 (114)	6.69 (170)

### Reel Weight

Less Cable

Example:

**C19 - A08 - D** 1102

REEL MODEL	WEIGHT lbs	WEIGHT (kg)
C19 - D	89	(40)
C19 - E	70	(32)
C19 - G	73	(33)
C19 - H	78	(35)
C19 - J	86	(39)
C19 - K	76	(34)

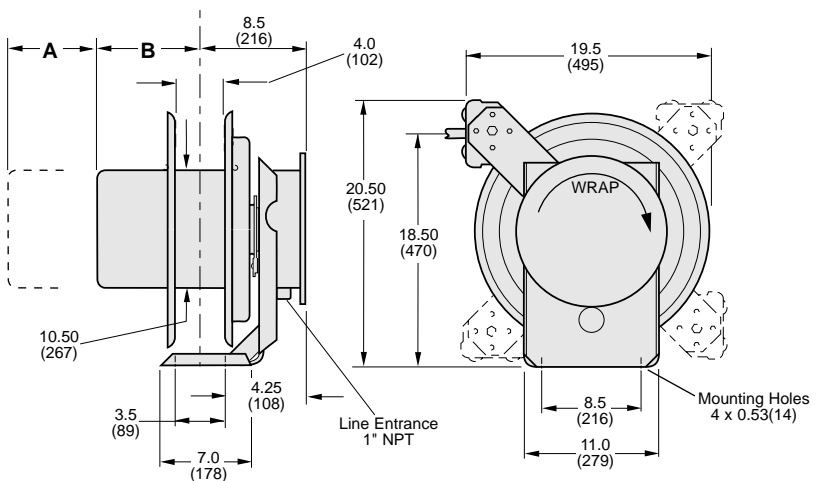

\* Wire size code is located in model number.

Example: C16 - **A** 03 - F1105 (A - F possible)

\*\* Number of slip ring poles is located in model number.

Example: C16 - **A03** - F1105 (01 - 12 possible)

# Accessories

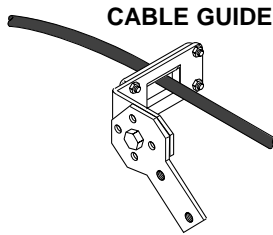

## CABLE GUIDE

One guide standard on each reel. Additional units may be fastened to supports away from reel to guide long runs of cable. Heavy steel with four nylon rollers.

REEL SERIES	MODEL NO.	WINDOW		
		W	x	H
C14	RG14	2.5(64)	x	1.25(31)
C16	RG16	3.0(76)	x	1.25(31)
C19	RG19	3.5(89)	x	1.25(31)



## CABLE STOP

Adjustable cable stop clamps onto cable to keep desired length of cable outside cable guide. Used only in hand pull applications. Black, neoprene rubber. Loosened or tightened with a standard screw-driver.

MODEL NUMBER	FITS O.D.s BETWEEN	
	in.	(mm)
CP-0	.25 - .46	(6-12)
CP-1	.47 - .56	(12-14)
CP-2	.57 - .69	(14-18)
CP-3	.70 - 1.0	(18-25)

## 340° PIVOT BASE (Optional)

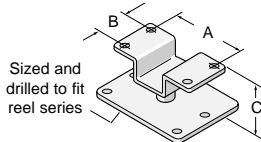

Sized and drilled to fit reel series

REEL SERIES	PIVOT BASE	HOLE DIA. in. mm	DIM. "A" in. mm	DIM. "B" in. mm	DIM. "C" in. mm
C14	#PB14	0.47 (11.9)	3.0 (76)	3.0 (76)	2.0 (51)
C16	#PB16	0.53 (13.5)	6.0 (152)	6.0 (152)	3.0 (76)
C19	#PB19	0.53 (13.5)	6.5 (165)	6.5 (165)	3.0 (76)

Aligns reel to the direction of cable run. Steel construction with orange polyester baked on finish. May be mounted with reel upright or hanging. Available for all models.

## KELLEMS® CABLE GRIP (Optional)

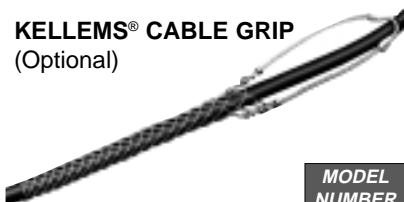

Stocking-type support prevents excessive strain on cable or pullout at connection point. Also absorb additional strain caused by flexure, vibration, expansion and contraction.

MODEL NUMBER	FITS O.D.s BETWEEN	
	in.	(mm)
CG01	0.5 - 0.6	(12-15)
CG02	0.6 - 0.7	(16-18)
CG03	0.75 - 1.0	(19-25)
CG04	1.0 - 1.2	(25-31)

## 360° SWIVEL BASE (Optional)

Allows full 360° swivel for all three, four or eight conductor C14 and C16 electric cable reels. Weathertight. Rated 600v. Rugged steel construction with orange polyester baked on finish. Includes 18"(457mm) flexible conduit and leads. Net weight 25 lbs.

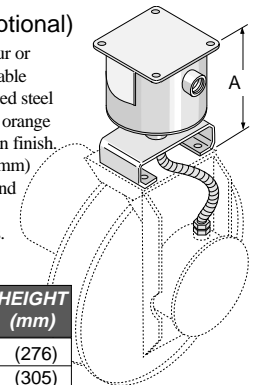
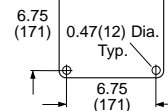

MODEL NUMBER	COND.	AMP.	O.A. HEIGHT in. (mm)
SB360-430	4	30	10.5 (276)
SB360-830	8	30	12.0 (305)
SB360-455	4	55	12.0 (305)

# Cable Data

## Type SO -600 VOLT

Refer to the National Electrical Code for ampere ratings and other details.

16 AWG.			14 AWG.			12 AWG.			10 AWG.		
NO. COND.	DIA. in. (mm)	WEIGHT/ft. lbs. (kg)	NO. COND.	DIA. in. (mm)	WEIGHT/ft. lbs. (kg)	NO. COND.	DIA. in. (mm)	WEIGHT/ft. lbs. (kg)	NO. COND.	DIA. in. (mm)	WEIGHT/ft. lbs. (kg)
2	0.374 (9)	0.094 (0.04)	2	0.512 (13)	0.158 (0.07)	2	0.586 (15)	0.204 (0.09)	2	0.638 (16)	0.250 (0.11)
3	0.393 (10)	0.110 (0.05)	3	0.538 (14)	0.184 (0.08)	3	0.616 (16)	0.244 (0.11)	3	0.671 (17)	0.310 (0.14)
4	0.427 (11)	0.144 (0.06)	4	0.584 (15)	0.224 (0.10)	4	0.668 (17)	0.282 (0.13)	4	0.730 (19)	0.371 (0.17)
5	0.510 (13)	0.156 (0.07)	5	0.665 (17)	0.160 (0.12)	5	0.725 (18)	0.322 (0.14)	5	0.796 (20)	0.425 (0.19)
6	0.565 (14)	0.178 (0.08)	6	0.710 (18)	0.302 (0.14)	6	0.805 (20)	0.380 (0.17)	6	0.883 (22)	0.485 (0.22)
7	0.605 (15)	0.202 (0.09)	7	0.710 (18)	0.329 (0.15)	7	0.865 (22)	0.435 (0.20)			
8	0.645 (16)	0.222 (0.10)	8	0.770 (20)	0.373 (0.17)	8	0.920 (23)	0.475 (0.21)			
9	0.720 (18)	0.268 (0.12)	9	0.820 (21)	0.414 (0.19)						
10	0.720 (18)	0.278 (0.13)	10	0.885 (22)	0.434 (0.20)						
12	0.740 (19)	0.305 (0.14)									

## Round Cable

### Type W 600 VOLT

8 AWG.			6 AWG.			4 AWG.		
NO. COND.	DIA. in. (mm)	WEIGHT/ft. lbs. (kg)	NO. COND.	DIA. in. (mm)	WEIGHT/ft. lbs. (kg)	NO. COND.	DIA. in. (mm)	WEIGHT/ft. lbs. (kg)
2	0.788 (20)	0.328 (0.15)	2	0.872 (22)	0.425 (0.19)	2	0.980 (25)	0.575 (0.26)
3	0.894 (23)	0.470 (0.21)	3	0.983 (25)	0.614 (0.28)	3	1.068 (27)	0.797 (0.36)
4	0.966 (25)	0.583 (0.26)	4	1.068 (27)	0.769 (0.35)	4	1.166 (30)	1.019 (0.46)

# Cable Management

Since 1911, Gleason Reel Corp. has been in the business of CABLE MANAGEMENT. Our products are designed to convey and protect valuable cables and hoses that power and control moving machines of all types. They improve productivity and safety on the job by moving cables and hoses away from hazardous locations on machinery or the shop floor into a controlled environment. Whether you choose Reels for efficient storage and payout from virtually any angle, Festoon Systems for overhead applications or PowerTrak® for protection on machinery in motion, your cables and/or hoses will last longer and provide better service with a cable management system from **Gleason Reel Corp...**

*...The Cable & Hose Management Company!*

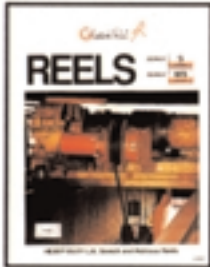

**Bulletin "CR"**  
Heavy Duty  
Spring Driven  
Electric Cable Reels  
General Industrial

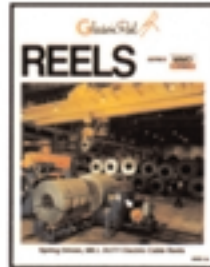

**Bulletin "MMD"**  
Mill Duty  
Spring Driven  
Electric Cable Reels  
Demanding Service

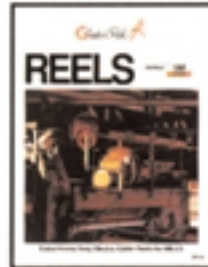

**Bulletin "SM"**  
Heavy Mill Duty  
Spring Driven  
Electric Cable Reels  
Steel Mill Service



**Bulletin "RET"**  
Long Travel Length  
Motor Driven  
Electric Cable Reels  
Standard Industrial



**Bulletin "PSR"**  
Lifting & Lowering  
Motor Driven  
Electric Cable Reels  
Push-Button Reels



**Bulletin "VMR"**  
Large Retrieving  
Motor Driven  
Electric Cable Reels  
Heavy Duty Industrial

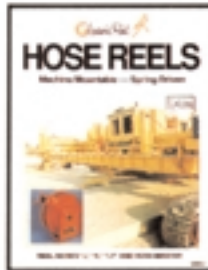

**Bulletin "HMR"**  
Various Types  
Spring Driven  
Hose Reels  
General Industrial



**Bulletin "SR"**  
Slip Rings  
Unitized Design  
Low & High Amperage  
Low & Medium Voltage



**Bulletin "PTG"**  
Non-Metallic  
Cable Chain  
For Hose & Cable  
Lightweight, Economical



**Bulletin "PT"**  
Rugged Steel  
Cable Chain  
For Hose & Cable  
Standard & Mill Duty



**Bulletin "FC"**  
Rugged Steel  
C-Rail Mounted  
Festoon Systems  
General Industrial



**Bulletin "FB"**  
Heavy Duty  
I-Rail Mounted  
Festoon Systems  
Heavy Duty Port Types



**HUBBELL** A Hubbell Company

**Gleason Reel Corp.**

P.O. Box 26 • 600 South Clark St.  
Mayville, Wisconsin 53050-0026  
Phone: 920-387-4120  
Fax: 920-387-4189

*In your area contact:*